



CAPSEAL

TAMPER-EVIDENT TIGHTENING SEAL

Description:

- Made of polyethylene
- Company logo and 8-digit sequential numbering
- Operating temperature: -50°C / +75°C
- Construction: monolithic tightening seal
- Laser marking through the thickness of the material
- For installation on new plastic faucets with a locking device; it has a bendable leaf with a tension hinge
- Diameter of the hole on the case: 7 mm (0.28")

Color options:

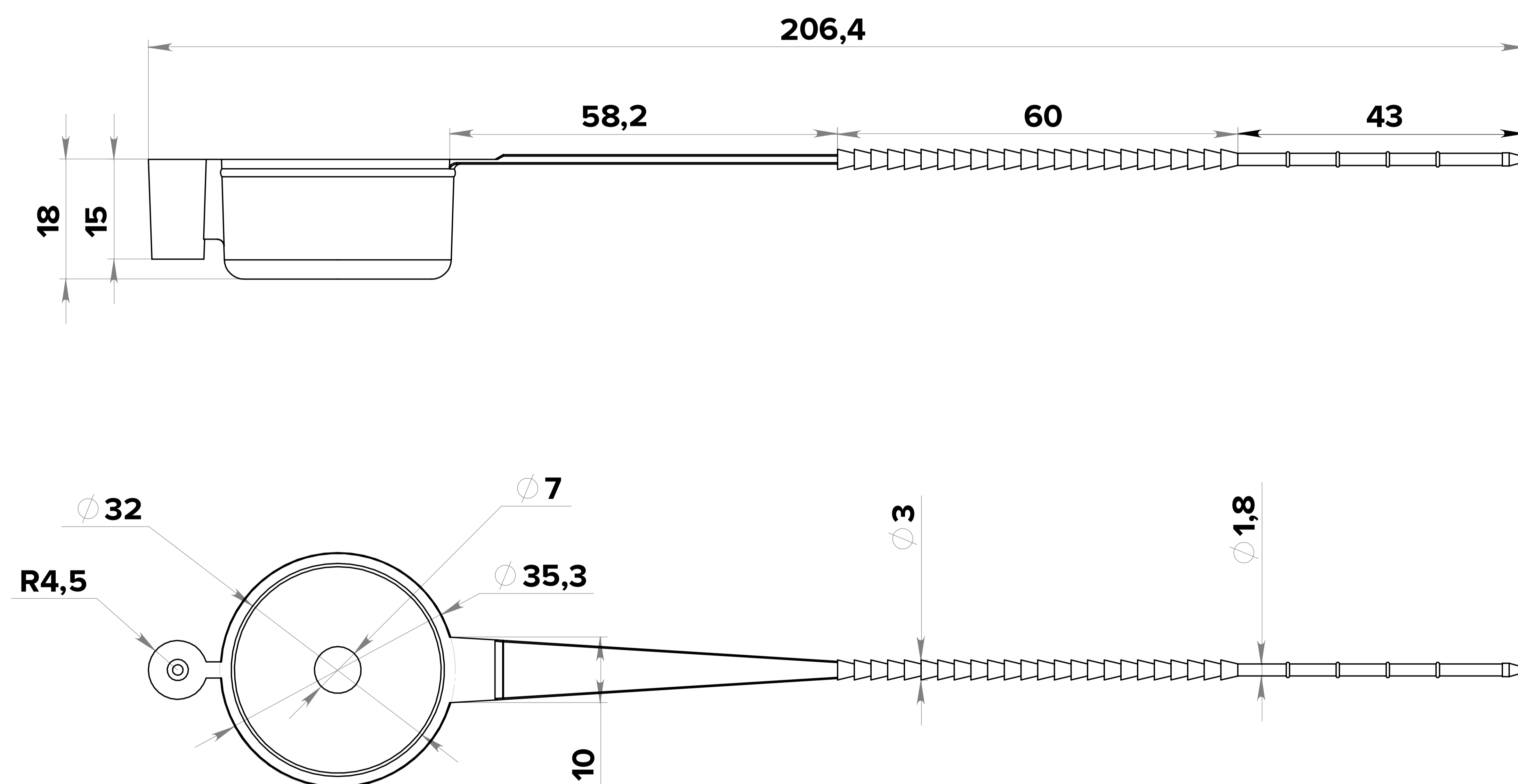

Package:	Size:	Quantity:	Weight:
Box	460×360×330mm (18.11×14.17×12.99")	0100-1,000 pcs.	kg (lbs.)